

SANTOS SAS :

140-150 AVENUE ROGER SALENGRO
69120 VAULX-EN-VELIN (LYON) - FRANCE
PHONE 33 (0) 472 37 35 29 -
FAX 33 (0) 478 26 58 21
E-Mail :santos@santos.fr www.santos.fr



CITRUS JUICER WITH LEVER N° 10

USER AND MAINTENANCE MANUAL



IMPORTANT: documents included in this manual to be kept:

- "CE" COMPLIANCE DECLARATION
- WARRANTY CERTIFICATE

ORIGINAL VERSION



Coffee grinders - Fruit juicers - Mixers - Blenders - Drinks dispensers - Planetary mixers
Cheese graters - Ice crushers - Mincers - Vegetable slicers - Dough mixer
Moulins à café - Presse-fruits - Mixers - Blenders - Distributeurs de boissons - Batteurs
mélangeurs - Pétrin - Râpes à fromage - Broyeurs à glaçons - Hache-viande - Coupe-légumes

MODELES DEPOSES FRANCE ET INTERNATIONAL
INTERNATIONALLY PATENTED MODELS





CONTENTS

“CE” COMPLIANCE DECLARATION 3

CITRUS JUICER WITH LEVER N°10..... 4

 RECYCLING THE PRODUCT AT THE END OF ITS SERVICE LIFE 4

 DO NOT: 4

 ELECTRICAL CONNECTION: 5

USING THE MACHINE 6

 PREPARING THE APPLIANCE FOR USE FOR THE 1ST TIME (FIG. A)..... 6

 USING FOR THE 1ST TIME: 6

Preparation and use: 6

 CLEANING 6

 MAINTENANCE 7

Spare parts: 7

FAULT FINDING 7

The machine will not start: 7

The appliance stops after the motor has overheated: 7

The appliance stops following an overload: 8

The motor operates but the cone does not rotate: 8

 REFERENCE TO STANDARDS 8

MACHINE TECHNICAL SPECIFICATIONS 9

 110-120V 50/60HZ WIRING DIAGRAM..... 10

 220-240V 50/60HZ WIRING DIAGRAM..... 11

WARRANTY CERTIFICATE 13

APPLIANCE IDENTIFICATION PLATE..... 13



"CE" COMPLIANCE DECLARATION

THE MANUFACTURER:

SANTOS SAS - 140-150, Av. Roger SALENGRO 69120 VAULX-EN-VELIN (LYON) - FRANCE

HEREBY DECLARES THAT THE MACHINE DESIGNATED ON THE IDENTIFICATION PLATE AFFIXED:

- UNDER THE APPLIANCE,
- ON THE WARRANTY CERTIFICATE ON THE LAST PAGE OF THIS MANUAL,

COMPLIES WITH THE PROVISIONS OF THE "machines" DIRECTIVE AS MODIFIED (Directive 98/37/CEI) AND THE NATIONAL LEGISLATION TRANSPOSING IT.

IT ALSO COMPLIES WITH THE PROVISIONS OF THE FOLLOWING EUROPEAN DIRECTIVES:

- No. 73/23 dated 19/02/73 (Low voltage directive)
- No. 89/336 (CEM directive)
- No. 2002/95/CE (RoHS directive)
- No. 2002/96/CE (DEEE directive)

The machine complies with the provisions of the following harmonized European standards:

- NF EN 12100-1 and 2:2004: Machine safety devices - General design principles
- NF EN 60204-1:1998: Machine safety devices - Machine electrical equipment - General regulations
- NF EN 60335-1:2003 Safety of household and similar electrical appliances

SIGNED IN VAULX-EN-VELIN ON: **01/01/2007**

SIGNATORY'S TITLE: **CHIEF EXECUTIVE OFFICER**

SIGNATORY'S NAME: **JACQUES FOUQUET**

SIGNATURE

CITRUS JUICER WITH LEVER N°10

- The Citrus Juicer n°10 is designed especially for bars, cafés, hotels, restaurants, cocktail bars, canteens, stores selling fresh fruit juices, ice cream parlors, etc
- The apparatus comprises the following elements (Fig. A):
 - cast aluminium motor unit (7),
 - stainless steel juice container (5),
 - stainless steel rotating cone (2),
 - a lever to press the fruit down (1),
 - mechanical clutch.
- Citrus Juicer n°10 is designed for extracting juice from oranges and lemons.
- It is ideal for making: drinks (fruit cocktails, punches, syrups, ...)

RECYCLING THE PRODUCT AT THE END OF ITS SERVICE LIFE



This appliance has the recycling symbol marking relating to waste electrical and electronic equipment. This means that this product must be processed by a waste sorting system in accordance with Directive 2002/96/CE (WEEE) – Professional Equipment section – so that it can be either recycled or disassembled in order to reduce any impact on the environment.

For further information, please contact your dealer or SANTOS..

For the disposal or recycling of the appliance components, please refer to a specialist company or contact SANTOS.

Electronic products which have not been out-sorted are potentially dangerous for the environment.

The packaging material should be disposed of or recycled in accordance with regulations in force.

DO NOT:



1. Do not use this appliance to squeeze anything other than oranges or lemons.
2. Do not apply pressure to a half-orange with the lever until after the On/Off switch has been put on position 1.

Note: You will find it easier to understand the next few paragraphs if you refer to the diagrams at the end of this manual.

ELECTRICAL CONNECTION:

- The appliance's power supply is available in two single-phase voltages:
 - 110-120 V 50/60 Hz: Model 10V1
 - 220-240 V 50/60 Hz: Model 10

Line protection: the appliance must be connected to a standard 2 pole + earth socket. The set-up must be fitted with a differential circuit breaker and a 16A fuse. **The earthing of the appliance is compulsory.**

TAKE CARE:

- Before connecting the machine, check that the mains electrical voltage is the same as the voltage for your appliance. Its value is shown:



- either on the identification plate under the machine.
- or on the identification plate on the last page of this manual.

- If the power cable is damaged, it should be replaced with a special unit available from SANTOS or a SANTOS-approved dealer.

TAKE CARE: Check that the On / Off switch (6) is in the **0 position** before connecting the power cable plug to your mains electric power socket.



USING THE MACHINE

PREPARING THE APPLIANCE FOR USE FOR THE 1st TIME (Fig. A).

Thoroughly clean all parts in contact with the food.

1. Raise the pressing lever right up (1)
2. Remove the cone by hand (2).
3. Wash with a standard dish washing product: the cone (2), the pressing cup (3), the splash guard (4) and the inside of the juice container (5).

USING FOR THE 1st TIME:

Preparation and use:

1. Cut the orange into two halves ready for squeezing.
2. Place the On/Off switch (6) at On. In this position the electric motor operates but the cone (2) is not rotated.
3. Position the half-orange on the cone (2).
4. Apply increasing pressure to the lever (1) for about 5 seconds. In this position, it is the pressure on the lever that (1) engages the clutch for the cone (2).
5. Release then lift the lever (1) and remove the orange skin from the cone.
6. Proceed in the same fashion for all the half-oranges to be squeezed.
7. **Take care:** When you have finished using the citrus fruit squeezer, stop it using the On/Off switch (6):

CLEANING

IMPORTANT:



- **Stop the appliance and unplug the power supply cable.**
- **The appliance should neither be cleaned in a jet of water nor with a high pressure spray**
- The motor unit (7) must not be immersed in water.

You are advised to clean the appliance as soon as it has finished being used.
It will be easier to clean if you do not allow the remaining scraps of food to dry.

1. Remove the cone (2) and rinse it under running water.
2. Rinse the juice container (5) with water, that can be collected in a glass placed on the glass-holder (8).
3. Finish off cleaning the container with a sponge.
4. Clean the pressing cup (3) with a sponge.
5. Remove the glass-holder (8) and rinse it under running water.
6. When more thorough cleaning is required, the pressing cup (3) must be removed. To do this, unscrew it by turning it anti-clockwise (Fig. B and Fig. C).

The base and the motor unit trim should be cleaned with a soft, damp sponge and then dried.

MAINTENANCE



Prior to carrying out any intervention on the appliance, it must be disconnected from the mains without fail.

Spare parts:

This machine requires no specific maintenance. The bearings are lubricated for life. If any intervention is necessary to replace parts subject to wear, such as the cone, the pressing cup electrical or other components, please refer to the parts lists (see the exploded view at the end of this manual).

For **all spare part orders** (see references in the exploded view at the end of the manual), state:

- **the type,**
- **the machine serial number and**
- **the electrical specifications**

recorded under the machine.

FAULT FINDING

First identify exactly why the machine stopped.

The machine will not start:

- Check : the mains supply, the condition of the supply cord and plug,
- Check that the On/Off lamp (6) lights up when the switch is at position 1. If it does not, replace the switch
- With the switch on position 0, check that the cone (2) can be easily rotated by hand.
 - If the cone does rotate, have the capacitor and the motor checked by a person qualified to do so.
 - If the cone does not rotate, have the clutch checked.

The appliance stops after the motor has overheated:

(the motor unit is hot)

The motor is protected by an integrated thermal cut-out system. If it overheats the motor stops.

- Put the On / Off switch (6) to the 0 position and unplug the machine.
- Wait for the motor to cool down (25 to 45 minutes) then press the On / Off switch (6) (position 1).

If the problem persists, switch off the power supply to the machine (unplug the cord from the mains socket) and call in the maintenance service or contact a SANTOS approved dealer.

The appliance stops following an overload:

- If the motor stalls during operation, release the pressure on the lever to allow it to start again.

If the problem persists, switch off the power supply to the machine (unplug the cord from the mains socket) and call in the maintenance service or contact a SANTOS approved dealer.

The motor operates but the cone does not rotate:

- Check the condition of the cone (2) drive pin (9) (Fig. D)
- Check that the clutch operates correctly (Fig. E) :
 - Start the appliance, with the switch at position 1
 - Raise the lever
 - Place the cone on the motor shaft (do not put any fruit on it)
 - With a piece of wood, press on the central part of the cone. The cone should move downwards a few millimeters and start to rotate.
 - If it does not, have the clutch checked.

REFERENCE TO STANDARDS

- CE (Europe)
- GS (Germany) checked by the LNE National Test Laboratory.
- UL (USA) and cUL (Canada).
- NSF (USA).



Machine Technical Specifications

ELECTRICAL SPECIFICATIONS (1)			
Model n° 10		Single phase	
Power supply voltage	(V)	220-240	110-120
Frequency	(Hz)	50/60	50/60
Motor Nominal			
Input power	(W)	230	260
Speed	(rpm)	1450	1700
Permanent capacitor	(mfd)	4 mfd - 400V	
Height of spout	(mm)	135	
Dimensions: Height	(mm)	380	
Width	(mm)	200	
Depth	(mm)	300	
Weight: Net weight	(kg)	9.2	
Packaged weight	(kg)	10.3	
Noise: (2)	(dBA)	70	

- (1) These ratings are given for your guidance. The exact electrical specifications of your appliance can be found on the rating plate.
- (2) Noise level measured in sound pressure appliance in operation 1 m from its axis in accordance with standard EN 31201.

MARK	Description
1	Pressure lever
2	Cone
3	Pressing cup
4	Splash guard
5	Juice container
6	On / Off switch
7	Motor unit
8	Glass holder
9	Pin

110-120V 50/60Hz wiring diagram

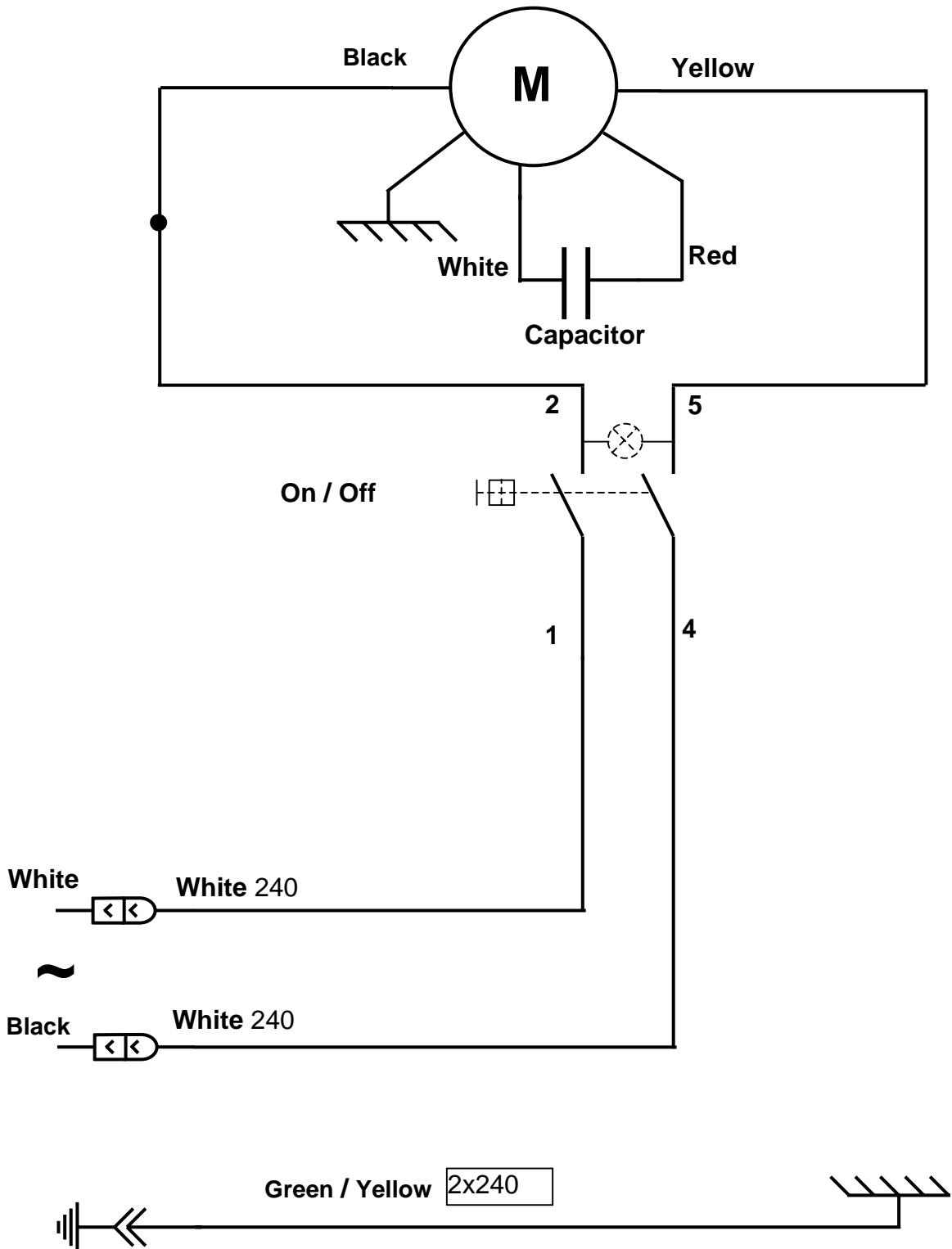

220-240V 50/60Hz wiring diagram

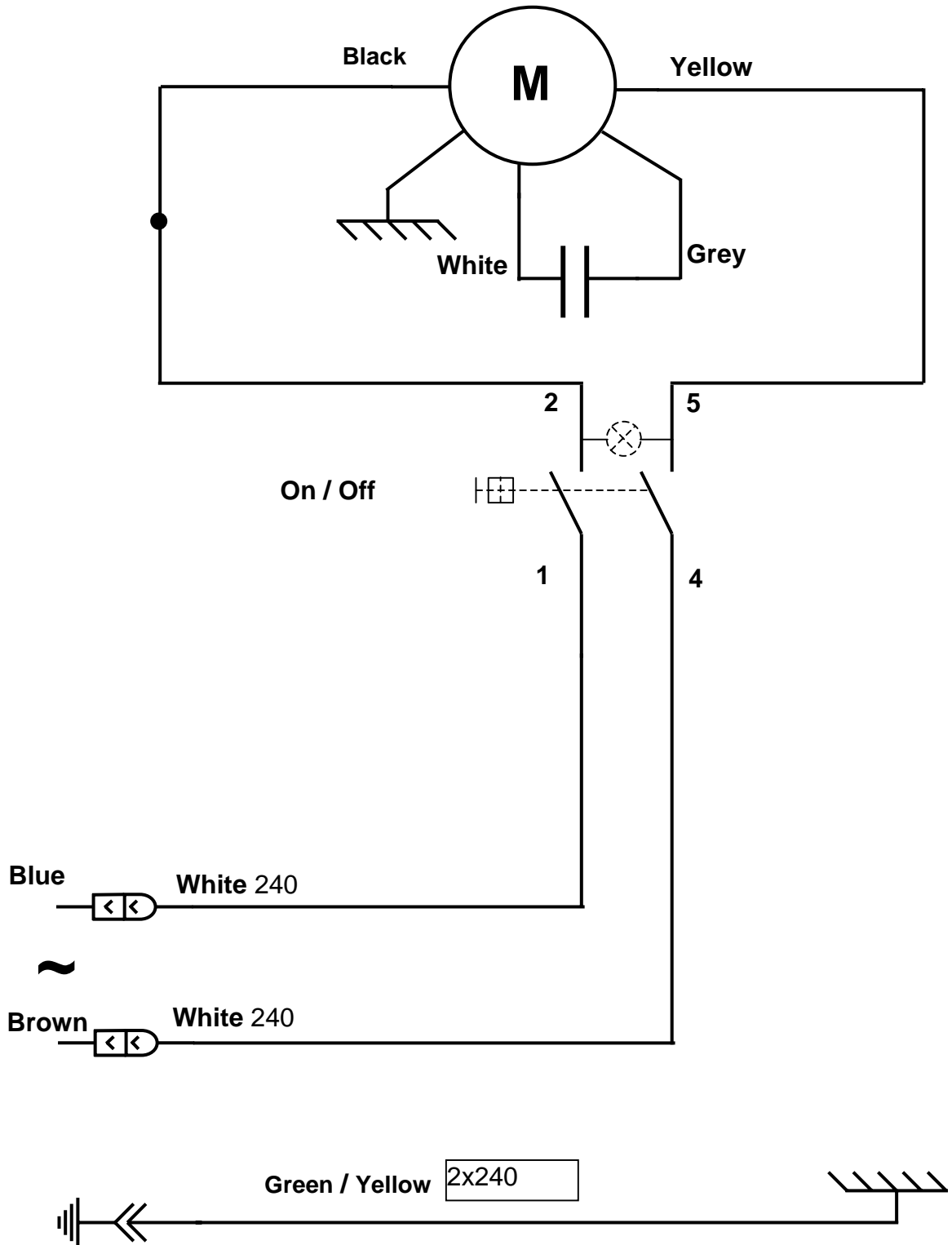

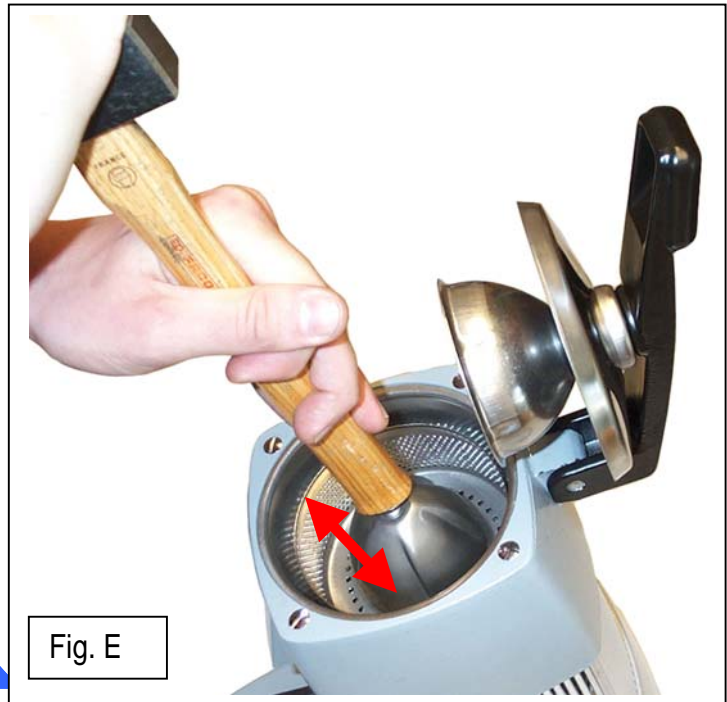
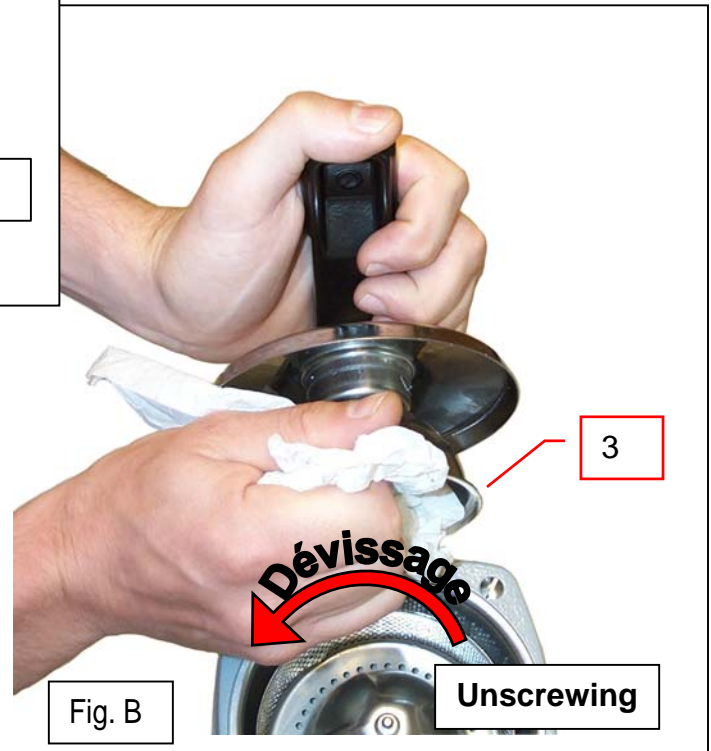
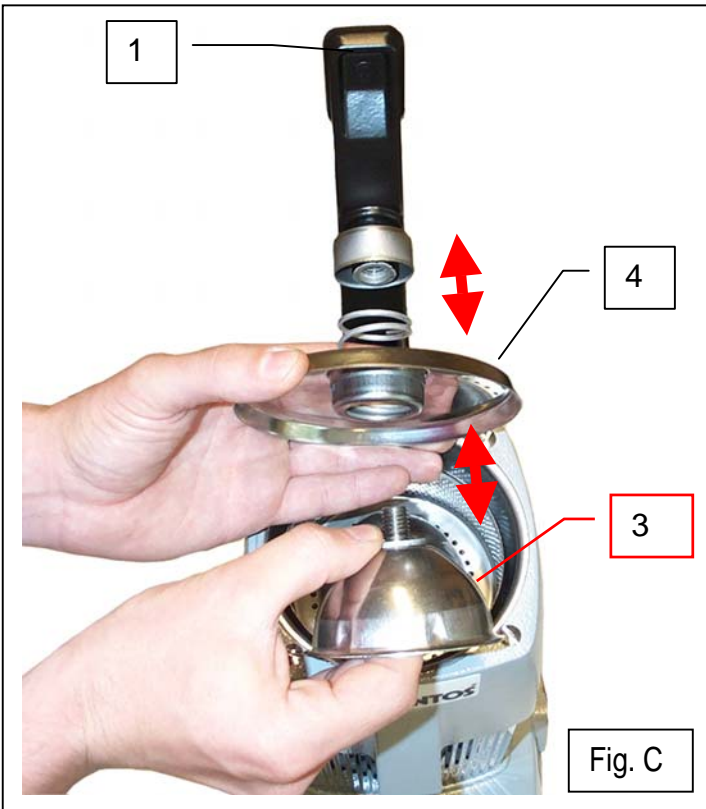
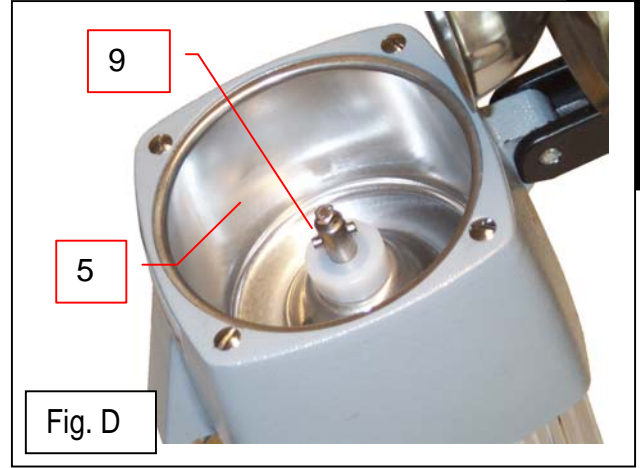
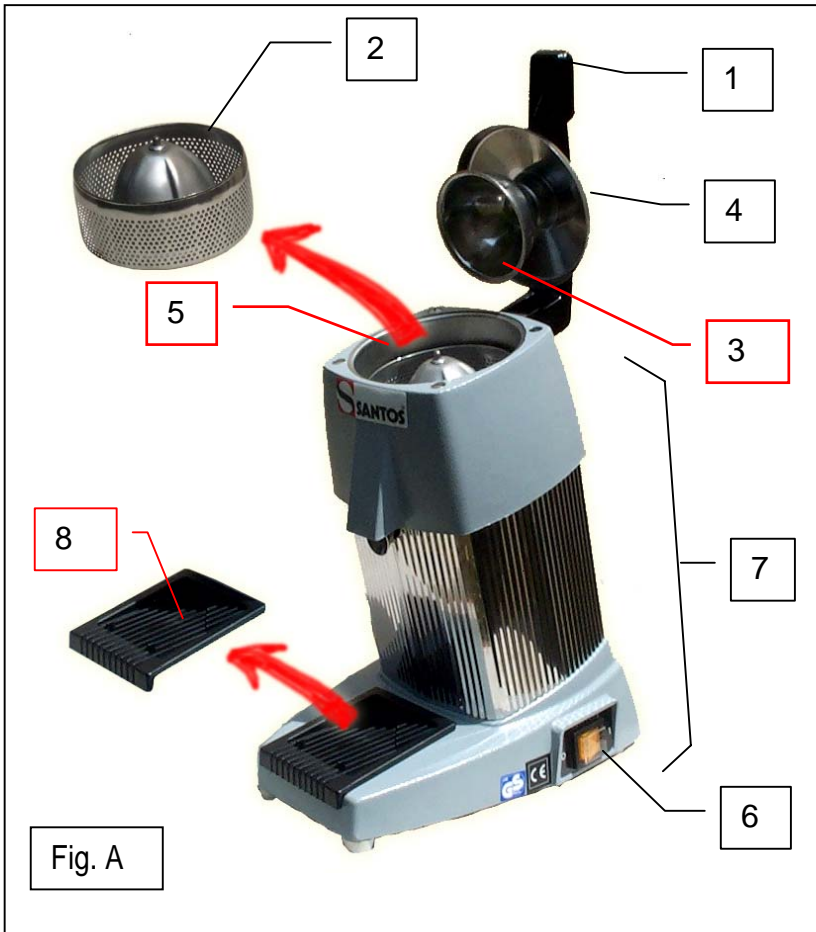



WARRANTY CERTIFICATE

WARRANTY

This appliance is guaranteed for twelve months from the date of manufacture appearing on the identification plate.

The guarantee is strictly limited to the free replacement of any original part acknowledged by us as being defective as a result of a fault or a manufacturing defect and identified as belonging to the appliance in question.

It does not apply to damage resulting from an installation or use which does not comply with the instructions supplied with each appliance (user manual) or in the event of an obvious lack of maintenance or non-observance of basic electrical safety rules.

All part replacements under warranty are made after return of the defective part to our workshops carriage paid, accompanied by a copy of this warranty certificate on which the serial number of the appliance is shown.

All appliances have an identification plate bearing a serial number identical to that on this warranty certificate.

In the event of serious damage which is deemed only to be repairable in our workshops, and after agreement from our services, all appliances under warranty are to be dispatched by the client carriage paid. If the appliance is repaired outside the warranty, the forwarding and return transport is the responsibility of the client. Parts and labour are invoiced at the prices in force (spare parts price - hourly labour cost). All repairs require a preliminary estimate that should be approved before the repairs are carried out.

In the event of a dispute, the Courts for the manufacturer's area (Lyon) alone have jurisdiction.

APPLIANCE IDENTIFICATION PLATE

