

WARING PRO[®]

PROFESSIONAL JUICE EXTRACTOR

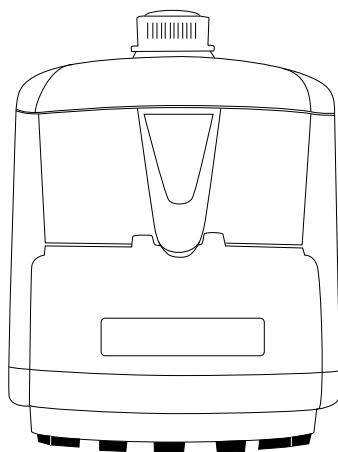

PJE & PJC SERIES

For your safety and continued enjoyment of this product,
always read the instruction book carefully before using.

CONTENTS

Important Safeguards	1
Disassembling	3
Assembling	3
Parts	4
A Delicious Nutritional Experience	4
Cleaning Instructions	5
Helpful Hints When Juicing	6
Important Facts You Should Know	6
Suggestions For Juice Combinations	7
Use of Pulp	8
Optional Citrus Juicer Attachment	8
Recipes	10

IMPORTANT: Always unplug the Waring Pro® Professional Juice Extractor from outlet when disassembling and assembling.

IMPORTANT SAFEGUARDS

- 1. READ ALL INSTRUCTIONS.**
- To protect against electrical hazards, do not immerse the Waring Pro® Juice Extractor in water or other liquid.
- This appliance should not be used by or near children or individuals with certain disabilities.
- Unplug from outlet when not in use, before putting on or taking off parts and before cleaning.
- Avoid contact with moving parts.
- Do not operate the Waring Pro® Juice Extractor or any other electrical equipment with a damaged cord or plug, or after the unit malfunctions, or is dropped or damaged in any manner. Return it to the nearest authorized service facility for examination, repair, or adjustment.
- The use of any attachments not recommended or sold by Waring may cause fire, electric shock, or injury.

8. Do not use outdoors.
9. Do not let power cord hang over edge of table or counter, or touch hot surfaces.
10. Always make sure juice extractor cover is secure beneath spring clips before motor is turned on. Do not loosen cover while juice extractor is in operation.
11. Be sure to turn switch to OFF position and unplug from outlet after each use of your juice extractor. Make sure the motor stops completely before disassembling.
12. Do not put your fingers or other objects into the juice extractor feed chute while extractor is in operation. If food becomes lodged in opening, use plunger or another piece of fruit or vegetable to push piece of food down. When this method doesn't work, turn the motor off, unplug from outlet and disassemble juice extractor to move any remaining food.
13. This appliance has a polarized plug (one blade is wider than the other). To reduce the risk of electric shock, this plug will fit in a polarized outlet only one way. If the plug does not fit fully in the outlet, reverse the plug. If it still does not fit, contact a qualified electrician. Do not modify the plug in any way.

IMPORTANT NOTE: For your safety and protection, this juice extractor is equipped with a thermal protector. Should your juice extractor overheat, the motor will automatically shut off. To restart, follow these steps:

- Move the toggle switch to the OFF position.
- Unplug juice extractor from electrical outlet.
- Let motor cool down for approximately 5 to 10 minutes.
- Once the motor has cooled down, plug unit into electrical outlet.
- Move toggle switch to ON position to continue juicing.

**SAVE THESE INSTRUCTIONS
FOR HOUSEHOLD USE ONLY**

DISASSEMBLING

Important: Juice extractor should be unplugged from outlet when disassembling.

- After removing your new juice extractor from the box, you may want to familiarize yourself with the parts by disassembling the unit and washing the top parts (pusher, cover, clutch, cutter blade, strainer basket, and juice collector bowl, see Figure 1).
- With juice extractor facing you (spout front), put your hands on both sides of the cover. Using the side arms for leverage, push back with your left hand and pull forward with your right, turning the cover clockwise. This will disengage the cover from the spring clips and disengage the lid safety interlock.
- Look into juice extractor and remove clutch by unscrewing counterclockwise.
- Lift out cutter blade.
- Lift out strainer basket.
- Lift off bowl.

ASSEMBLING

- Place bowl on motor base housing and place the spout facing front between the two raised projections on the motor base housing.
- Place strainer basket inside the bowl over the hex drive. Be certain the strainer basket sits flat.
- Place cutter blade inside strainer basket with teeth up.
- Tighten clutch finger until it is tight or snug.
- If using disposable filter, insert it flat against the holes around the inside of the strainer basket. Once the juice extractor is running, centrifugal force will push the filter into perfect position.
- Place cover on bowl with feed chute at the rear, grip the sides of the lid firmly and turn counter clockwise to engage the spring clips and the safety interlock.
- **IMPORTANT NOTE:** The juice extractor will not operate until the cover is properly assembled to the unit.

PARTS

1. Pusher
2. Cover
3. Clutch
4. Cutter Blade
5. Strainer Basket
6. Juice Collector Bowl
7. Base
8. ON/OFF Switch (not shown)
9. Citrus Juice Attachment
(Included with model PJC44)
10. Drip Spout
11. Safety Interlock Switch (hidden)

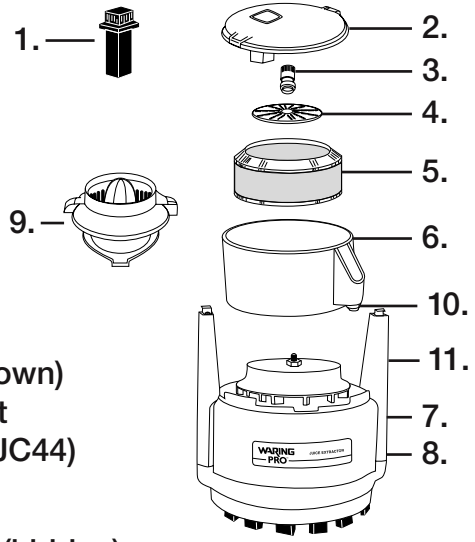

Fig. 1

A DELICIOUS NUTRITIONAL EXPERIENCE AWAITS YOU AND YOUR FAMILY

Raw juices derived from fresh fruits and vegetables are invaluable as an aid in the maintenance of a balanced diet. Raw juice is easily assimilated and contains, in a most natural and complete form, precious vitamins, minerals, bioflavonoids and enzymes. Nutritional authorities state that raw juice is food in an easily digestible form.

Be sure to use your Waring Pro® Professional Juice Extractor daily, or as often as you can manage, in the manner recommended in this instruction manual.

Because of the cleansing and rebuilding properties contained in juices, it is recommended that you use juices in small amounts the first week and then gradually increase the amounts as you can comfortably enjoy them.

Vegetable juices can be mixed, but if fruit juices are added, do not use more than one kind. We recommend that fruit juices be taken alone, between meals, and at room temperature.

For further information on the consumption of juices, we recommend that you visit your health food store or book store and pick up one or more of the many books available on juicing.

The Waring Pro® Professional Juice Extractor is the result of years of intensive research and scientific developments, and we feel sure you will be delighted with its precision performance.

LID SAFETY INTERLOCK

The safety interlock switch prevents operation of the machine unless the lid is in its proper position.

CLEANING INSTRUCTIONS

- Follow disassembling instructions.
- Use cool or cold tap water when washing.
- The plunger, cover, bowl, and clutch only require rinsing.
- Blade should be washed under running water, using a stiff brush.
- After removing most of the pulp and filter (if used) from strainer basket using a spoon, your hands, or the disposable filter, hold basket under cold running water while you brush the holes from the outside. After the holes are clean, take a damp sponge or towel and wipe out the remaining particles. All stainless steel parts are dishwasher safe. Plastic parts may be placed on top rack of dishwasher.

NOTE: In case mineral stains appear after repeated use, soak the cover, bowl, strainer basket, cutter blade, and clutch overnight in cold water into which Cascade® detergent (8 tablespoons to a gallon of water) has been dissolved. Make sure all parts soaking are completely covered with water.

HELPFUL HINTS WHEN JUICING

The Waring Pro® Juice Extractor is a precision made machine. The following hints will help you get optimum performance from your extractor.

- Vegetables should always be fresh and crisp. All fruits and vegetables should be fed into the feed chute as illustrated in Figure 2. Feed all vegetables in the largest pieces possible. With hard fruits and vegetables (carrots, beets, celery, etc.), we recommend feeding through using a hard, uneven motion.
- For optimum juicing with leafy vegetables, we recommend that they be rolled up and then processed.
- With softer fruits and vegetables such as apples, we recommend a slow, even motion when pushing down the feed chute to allow the skins to be torn apart completely.

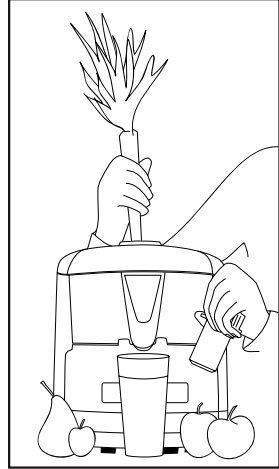

Fig. 2

IMPORTANT FACTS YOU SHOULD KNOW ABOUT YOUR JUICE EXTRACTOR

- Your Waring Pro® Juice Extractor has a permanently lubricated induction motor and should never be oiled.
- Do not put any parts of your Waring Pro® Juice Extractor on the stove or in the oven.
- Be sure strainer basket and cutter blade are dry for proper processing.
- When placing the cover on top of the machine, make sure the feed chute is to the rear of the machine.
- After you finish feeding through the vegetables, turn

machine off and allow the machine to come to a complete stop for maximum juice extraction.

- The amount of juice you can make before emptying Strainer Basket depends on what you are juicing and the amount of juice that the fruit or vegetable contains.
- For easier cleaning, disposable filters are available. (See card insert and samples enclosed.) Filtering is most effective when juicing softer fruits and vegetables, or when making only a few glasses of juice at one time.
- For juicing all citrus fruits, we advise the use of the Citrus Juicer Attachment (PCA45) that fits the Waring Pro® Juice Extractor. See Figure 3.

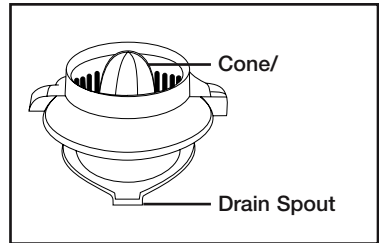

Fig. 3

SUGGESTIONS FOR JUICE COMBINATIONS

Most everyone enjoys the juice in its fresh form just as it comes from the juice extractor. If this is not the case with you, you can combine different juices in proportions to suit your taste. After experimenting with different juices, every member of the family will find the combinations that he or she enjoys. It is very much a matter of individual taste, and ideas of taste-tempting juice combinations vary considerably.

Vegetable and fruit cocktails can be enjoyed at any time. Nothing surpasses them for helping to quicken energy, and they are delicious, nutritious drinks.

Here are some tasty juice combinations you may wish to try:

- $\frac{2}{3}$ carrot juice with $\frac{1}{3}$ celery juice. For improved flavor, add a few drops of lemon juice.

- ½ carrot juice with ½ apple juice
- ¾ carrot juice with ¼ cabbage juice
- ⅔ celery juice with ⅓ apple juice
- 5 oz. carrot juice with 2 oz. cucumber juice and 1 oz. beet juice
- 4 oz. carrot juice with 3 oz. celery juice and 1 oz. parsley juice (or any leafy green juice)
- 6 oz. apple juice with 8 oz. carrot juice and 2 oz. spinach juice
- 2 oz. carrot juice with 4 oz. apple juice and 2 oz. cabbage juice
- 7 oz. celery juice with 1 oz. lemon juice

USE OF PULP

With the Waring Pro® Juice Extractor, nothing is wasted. The leftover pulp may be used for flavoring in soups, casseroles, breads, cakes, salads, and Jello molds.

Many people also use the pulp as compost for gardens, shrubbery, flowers and plants.

OPTIONAL CITRUS JUICER ATTACHMENT (PCA45)

An optional citrus juicer attachment is available to enable you to easily juice citrus fruits with your Waring Pro® Juice Extractor. (The citrus attachment is included with the Waring Pro® Juicing Center model PJC44.)

- Before using the citrus juicer attachment, remove cover, clutch, cutter blade, and strainer basket from the juice extractor. These parts are not used with the citrus juicer attachment.
- Following Figure 4, place citrus juicer attachment on juice extractor bowl with drain spout to the left of center front, and turn the Attachment counterclockwise to secure beneath spring clips. The drain spout

will then line up with the bowl spout. Be sure that the cone/strainer is firmly seated in the citrus juicer attachment.

- Turn on juice extractor switch, and allow a few seconds for motor to reach normal speed before juicing.

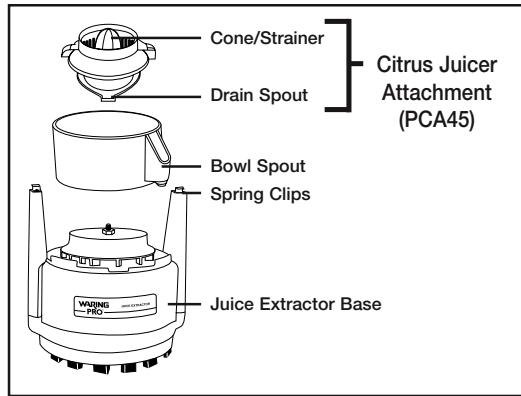

Fig. 4

- Cut citrus fruit in half crosswise. Place fruit, cut side down, on the cone/strainer and push down firmly. Cone/strainer will not turn until pressure is applied. Cone/strainer will stop turning when pressure is released. **CAUTION: Keep fingers away from moving parts.**
- For cleaning, turn the attachment clockwise to release from spring clips. Remove the attachment, take cone/strainer out, and place both bottom side up under running water, or place on top rack of dishwasher.
- After removing the attachment, remove the juice extractor bowl and rinse with cool water, or place on top rack of dishwasher.

RECIPES

Apple Tea

Courtesy of Burt Wolf, New York City

- 1 quart cold water
- 8 tea bags
- 2 cups freshly extracted apple juice
- juice of 1 lemon

Fill a pitcher with cold water. Place the tea bags in the pitcher. Cover the pitcher and let it stand overnight at room temperature.

The following day, remove the tea bags. Add the apple juice and the lemon juice and stir.

Makes 4 servings.

Adam's Kiss

Courtesy of Southampton Princess Hotel, Bermuda

- ¼ cup sugar
- ⅛ cup water
- 1 quart freshly extracted apple juice
- 1 cup orange juice
- 1 cup cranberry juice cocktail
- 1 pint fresh strawberries
- 1 liter bottle chilled club soda
- ½ lime, thinly sliced

In a saucepan, bring the sugar and water to a boil. Simmer for 5 minutes and then cool.

Put one dozen ice cubes in a punch bowl large enough to hold all the ingredients. Pour in the sugar syrup, the apple juice and the orange and cranberry juice.

Add the strawberries and stir.

Pour in the club soda, then garnish the punch with the lime slices and serve.

Makes 10 servings.

Any trademarks or service marks of third parties used herein are the trademarks or service marks of their respective owners.

© 2007 Waring Products
Division of Conair Corporation
150 Milford Road
East Windsor, NJ 08520
www.waringproducts.com

Printed in China
07wr32054

IB-026188