

robot  ***coupe***®



J 80 Ultra

SUMMARY

■ **WARRANTY**

■ **IMPORTANT WARNING**

■ **YOU HAVE JUST PURCHASED
A J 80 Ultra
CENTRIFUGAL JUICER**

■ **SWITCHING ON THE MACHINE**

■ **ASSEMBLY**

■ **RECOMMENDATIONS FOR USE**

■ **CLEANING**

■ **TECHNICAL SPECIFICATIONS**

- Weight
- Dimensions
- Working height
- Noise level
- Electrical data

■ **SAFETY**

■ **TROUBLESHOOTING**

■ **STANDARDS**

■ **RECIPES**

■ **TECHNICAL DATA**

- Exploded views
- Electric and wiring diagrams

ROBOT-COUCPE S.N.C., LIMITED WARRANTY

Your new ROBOT-COUCPE appliance is warranted to the original buyer for a period of one year from the date of sale if you bought it from ROBOT-COUCPE S.N.C.

If you bought your ROBOT-COUCPE product from a distributor your product is covered by your distributor's warranty (Please check with your distributor terms and conditions of the warranty).

The ROBOT-COUCPE S.N.C. limited warranty is against defects in material and/or workmanship.

THE FOLLOWING ARE NOT COVERED BY THE ROBOT-COUCPE S.N.C. WARRANTY:

1 - Damage caused by abuse, misuse, dropping, or other similar damage caused by or resulting from failure to follow assembly, operating, cleaning, user maintenance or storage instructions.

2 - Labour to sharpen and/ or replacements for blades which have become blunt, chipped or worn after a normal or excessive period of use.

3 - Materials or labour to replace or repair scratched, stained, chipped, pitted, dented or discoloured surfaces, blades, knives, attachments or accessories.

4 - Any alteration, addition or repair that has not been carried out by the company or an approved service agency.

5 - Transportation of the appliance to or from an approved service agency.

6 - Labour charges to install or test new attachments or accessories (i.e., bowls, discs, blades, attachments) which have been arbitrarily replaced.

7 - The cost of changing direction-of-rotation of three-phase electric motors (Installer is responsible).

8 - SHIPPING DAMAGES. Visible and latent defects are the responsibility of the freight carrier. The consignee must inform the carrier and consignor immediately, or upon discovery in the case of latent defects.

KEEP ALL ORIGINAL CONTAINERS AND PACKING MATERIALS FOR CARRIER INSPECTION.

Neither ROBOT-COUCPE S.N.C. nor its affiliated companies or any of its distributors, directors, agents, employees, or insurers will be liable for indirect damage, losses, or expenses linked to the appliance or the inability to use it.

The ROBOT-COUCPE S.N.C. warranty is given expressly and in lieu of all other warranties, expressed or implied, for merchantability and for fitness toward a particular purpose and constitutes the only warranty made by ROBOT-COUCPE S.N.C. France.

IMPORTANT WARNING



WARNING : In order to limit accidents such as electric shocks or personal injury, and in order to limit material damage due to misuse of the appliance, please read these instructions carefully and follow them strictly. Reading the operating instructions will help you get to know your appliance and enable you to use the equipment correctly. Please read these instructions in their entirety and make sure that anyone else who may use the appliance also reads them beforehand.

UNPACKING

- Carefully remove the equipment from the packaging and take out all the boxes or packets containing attachments or specific items.
- **WARNING** - some of the tools are very sharp e.g. blades, discs... etc.

INSTALLATION

- We recommend you install your machine on a perfectly stable solid base.

CONNECTION

- Always check that your mains supply corresponds to that indicated on the identification plate on the motor unit and that it can withstand the amperage.
- The machine must be earthed.

HANDLING

- Always take care when handling the blades, as they are extremely sharp.

ASSEMBLY PROCEDURES

- Follow the various assembly procedures carefully (see page 17) and make sure that all the attachments are correctly positioned.

USE

- Never try to override the locking and safety systems.
- Never insert an object into the container where the food is being processed.
- Never handily push the ingredients inside the feed hopper.
- Do not overload the appliance.
- Never switch the appliance on when it is empty.

CLEANING

- As a precaution, always unplug your appliance before cleaning it.
- Always clean the appliance and its attachments at the end of each cycle.
- Never immerse the motor unit in water.
- For parts made from aluminum, use cleaning fluids intended for aluminum.

- For plastic parts , do not use detergents that are too alkaline (e.g., containing too much caustic soda or ammonia).
- Robot-Coupe can in no way be held responsible for the user's failure to follow the basic rules of cleaning and hygiene.

MAINTENANCE

- Before opening the motor housing, it is absolutely vital to unplug the appliance.
- Check the seals and washers regularly and ensure that the safety devices are in good working order.
- It is particularly important to maintain and check the attachments since certain ingredients contain corrosive agents, e.g. citric acid.
- Never operate the appliance if the power cord or plug has been damaged or if the appliance fails to work properly or has been damaged in any way.
- Do not hesitate to contact your local Maintenance Service if something appears to be wrong.

YOU HAVE JUST PURCHASED A J 80 Ultra CENTRIFUGAL JUICER

With its sturdy and stable design, the **J 80 Ultra** offers the **perfect juicing-on-demand solution**, capable of producing **an exciting range of totally natural juices!**

The **J 80 Ultra** is ideal for quickly preparing exotic and non-exotic fruit juices, as well as any number of vegetable juices and sophisticated juice cocktails.

It therefore has applications in bars, restaurants, canteens, residential homes and day nurseries, as well as in clinics and diet kitchens, where fresh fruit and vegetable juices have a key role to play.

Both fruit and vegetables, especially when raw, are a valuable source of the vitamins, minerals and fibres we need to stay healthy. Vegetable juices mainly contain mineral salts, while fruit juices are bursting with energy-boosting vitamins.

MINERAL SALTS

Mineral content varies widely from one type of food to another.

While a mixed diet will provide you with the necessary amount of some minerals, such as potassium, magnesium, sulphur and sodium chloride (salt), for other minerals, it is useful to know which foods are the best sources.

Calcium: fruit and green vegetables.

Phosphorus: pulses.

Potassium: fresh vegetables.

Iron: spinach, parsley.

Iodine: all fruit and vegetables.

TABLE OF VITAMINS IN FRUIT

Vitamins	B1	C	A	D
Apple	•	•		•
Apricot	•	•	•	•
Blackberry	•	•	•	•
Blackcurrant	•	•		•
Cherry	•	•	•	•
Grape	•	•		•
Grapefruit	•	•	•	•
Kiwi	•	•	•	•
Lemon	•	•	•	•
Melon	•	•		•
Orange	•	•	•	•
Peach	•	•		•
Pear	•	•		•
Pineapple	•	•	•	•
Plum	•	•		•
Raspberry	•	•		•
Redcurrant	•	•		•
Strawberry	•	•		•

TABLE OF VITAMINS IN VEGETABLES

Vitamins	B1/B6	A	E	K
Asparagus	•		•	
Cabbage	•	•	•	•
Carrot	•	•	•	
Celeriac	•			
Celery		•	•	•
Chicory	•			
Courgette	•	•	•	
Cucumber	•	•	•	
Fennel	•		•	
Lettuce	•		•	
Onion	•			
Parsley	•	•	•	
Pepper	•	•	•	
Spinach	•	•	•	•
Tomato	•	•		
Turnip	•			
Watercress	•	•	•	

This appliance has been given a deliberately simple design so that the parts which are most frequently handled can be easily removed and reassembled for cleaning and aftercare.

To help you do this, we have included a set of step-by-step assembly instructions in this booklet.

This booklet contains important information intended to enable users to get the most from their investment in this juicer.

Therefore, please read these instructions through carefully before use.

SWITCHING ON THE MACHINE

Before connecting this appliance to the mains, check that your electrical power supply corresponds to the data shown on the motor identification plate.

The **J 80 Ultra** juicer is supplied with a power cord fitted with a single-phase moulded plug.

You must never operate your appliance if it has been damaged in any way.



WARNING

This appliance must be plugged into an earthed socket (risk of electrocution).



ASSEMBLY



1) Place the motor unit so that it is facing you.

2) Position the bowl on top of the motor unit.



3) Fit the flange on top of the bowl.

4) Position the juicer basket, holding it by the scraper clips. Rotate it until it slots into position.



5) Line the lid up with the notches in the flange.

6) Position the pulp container.



7) Insert the pusher.

8) Close the safety arm. To switch the juicer on, push the switch.

The machine will not start unless the safety arm has been properly closed (safety switch).

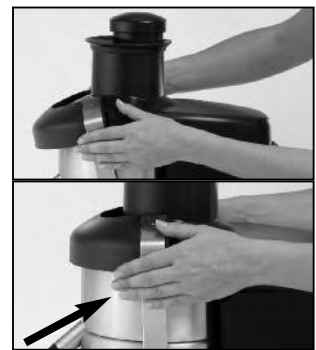

Place a container under the pouring spout. Your juicer is now ready for action!

RECOMMENDATIONS FOR USE

- Before using your appliance for the first time, clean all the parts that will come into contact with food.
- Always check that the safety arm has been closed properly before use.
- Switch your juicer on and place a container under each spout before feeding any ingredients in.
- Before using your appliance for the first time, rinse it through several times with hot water, with or without two peeled lemons cut into chunks. Your appliance will then be ready for use.
- Never feed the ingredients in too quickly.

WARNING

Always wash the fruit and vegetables thoroughly to remove all chemical traces.

- Always peel citrus fruits before placing them in the feed tube.
- Thick-skinned fruit and vegetables (e.g. pineapples) should always be peeled and any large seeds removed (e.g. melons). Always remove pits from stone fruit (e.g. apricots, peaches, cherries).
- Feed the fruit and vegetable chunks into the tube little by little.
- Always leave the appliance running for a few seconds after the last of the ingredients has been fed in, in order to extract every last drop of juice.

- Never place ice cubes or frozen fruit in the feed tube.
- If the pulp is unevenly distributed in the basket, it may create an imbalance. Accordingly, if the juicer starts to vibrate while running, switch it off and empty the basket. You can then switch the appliance back on. If the spout becomes blocked, switch the juicer off, rinse out the basket and resume operations.
- Always check that the flange and lid have been correctly positioned.

CLEANING

As a precaution, we recommend that you unplug the machine before undertaking any cleaning operation.

Always unplug the appliance before cleaning.

If you wish to clean the appliance before use, plug it back in, pour some hot water in via the lid, switch the juicer on and leave it running for a few seconds.

Always clean your appliance thoroughly after use, rinsing the flange, juicer basket, lid and pusher in hot water and scrubbing them with a brush.

IMPORTANT

Check that your detergent is suitable for cleaning plastic parts. Some washing agents are too alkaline (e.g. high levels of caustic soda or ammonia) and totally incompatible with certain types of plastic, causing them to deteriorate rapidly.



IMPORTANT

Never immerse the motor unit in water or in any other liquid and do not splash it!

Do not clean it with a water spray.

If necessary, wipe the housing clean with a damp cloth.

Always unplug the appliance before cleaning.

When juicing vegetables, especially carrots, the sieve tends to get clogged with pulp, thereby reducing the flow of juice. For this reason, the juicer basket must be cleaned at regular intervals. To do so, immerse the basket in hot water with a few drop of washing-up liquid and scrub with a brush. After cleaning, reassemble the machine.

TECHNICAL SPECIFICATIONS

- **Motor unit** —————> stainless steel
- **Bowl** —————> stainless steel
- **Juicer basket** —————> stainless steel
- **Grater disc** —————> stainless steel
- **Ventilated electric motor** —————> constant speed (3.000 rpm)
- **Throughput** —————> 100-120 kg fruit / vegetables* per hour

* In optimum operating conditions, i.e. a suitable worktop, ready-prepared ingredients and all accessories conveniently to hand (jug, waste bin, etc.).

• **WEIGHT**

	Net	Gross
J 80 Ultra	10.9 kg	12.8 kg

• **DIMENSIONS (in mm)**

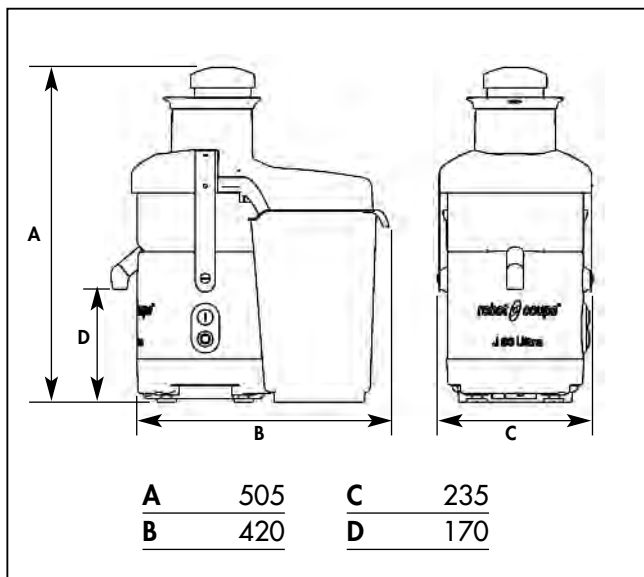

• **WORKING HEIGHT**

We recommend that you install your J 80 Ultra juicer on a stable, level surface.

• **NOISE LEVEL**

The appliance's equivalent continuous sound level when running empty is below 70 db (A).

• **ELECTRICAL DATA**

Motor	Speed (rpm)	Power (watts)	Intensity (Amp.)
230 V/50 Hz	3000	700	7

SAFETY

The machine will not start unless the lid has been correctly positioned and the safety arm properly closed. The motor automatically switches itself off as soon as the safety arm is opened.

To switch the machine back on, simply lock the lid and safety arm back into position and press the switch.

All our appliances are fitted with a thermal failsafe which automatically switches the motor off if it has been left running for too long or is in overload.

If this occurs, you must wait until the appliance has cooled down before switching it back on.

You must never use the machine without the pusher or insert a solid object into either the feed tube or the ejector spout.

Never unplug the machine with wet hands or by tugging on the power cord.

! REMEMBER

- Never try to override the locking and safety systems.
- Never insert an object into the container where the food is being processed.
- Never push the ingredients down with your hand.
- Do not overload the appliance.
- Never switch the appliance on when it is empty.

In order to avoid accidents and damage to the appliance, always push the fruit and vegetables to the bottom of the feed tube with the pusher intended for that purpose. Never do so with your hands or with another implement!

TROUBLESHOOTING

SYMPTOMS	CAUSES AND/OR REMEDIES
The appliance will not start.	<ul style="list-style-type: none"> - Plug the power cord into a wall socket. - Close the safety arm properly. - Press the switch off then on. - Begin by checking your power supply fuses.
You can hear something rubbing.	- The appliance has not been assembled correctly. See "Assembly" chapter.
Considerable pressure has to be exerted on the pusher.	<ul style="list-style-type: none"> - The grater disc inside the appliance has become worn and needs replacing. - The fruit and vegetables are not being fed in properly.
The appliance vibrates.	- Either the flange, the pouring spout or the ejector spout has become blocked.
The noise level is abnormally high.	- The motor is faulty and needs repairing.
The basket fails to stop moving immediately after the safety arm has been opened.	- Replace the electrical circuit.

STANDARDS

MACHINES IN COMPLIANCE WITH:

- The following European directives and related national legislation:
 - Modified "machinery" directive 2006/42/EC,
 - "Low voltage" directive 2006/95/EEC,
 - "EMC" directive 2004/108/EC,
 - "Materials and parts in food contact" directive 89/109/EEC,
 - Commission Directive 2002/72/EC of 6 August 2002 relating to plastic materials and articles intended to come into contact with foodstuffs.
 - "ROHS" directive 2002/95/CE,
 - "DEEE" directive 2002/96/CE.
- The following European harmonized standards and standards setting out health and safety rules:
 - ISO 12100 - 1 and - 2 - 2003,
 - EN 60204 -1 (2006),
 - For Vegetable cutting machine : EN 1678 - 1998.

INDEXES OF PROTECTION:

- IP 55 for the switches.
- IP 34 for the machines.

RECIPES

Fruit and vegetables can be combined in an infinite number of ways to create exciting, colourful and totally natural drinks. Give your imagination free rein - bearing in mind these few golden rules for making cocktails:

- Always use untreated fruit.
- Using a shaker will make an opaque mixture more homogeneous.
- Fill the lower half of the shaker half-full with ice cubes. Avoid shaking your cocktail for too long, otherwise the ice will melt and spoil it.

Here is a selection of cocktail recipes, each for approximately four people.

FRUIT COCKTAILS

LOOKING GOOD

Ingrédients (for 3 glasses):

- 2 carrots
- 2 green apples
- 1 lime

Peel the lime. Process the apples, carrots and lime in your J 80 Ultra juicer.

RED COCKTAIL

Ingrédients (for 3 glasses):

- 1 fresh, medium-sized beetroot
- 1 carrot
- 1 small bunch red grapes
- 1 organically-grown apple

Peel the vegetables and strip the grapes off the bunch. Process all the ingredients in your J 80 Ultra juicer. Season with Cayenne pepper.

SOOTHING SMOOTHIE

Ingrédients (for 4 glasses):

- 1 ripe mango
- 2 kiwi fruit
- 2 yoghurts
- 2 tablespoons honey

Peel the mango and remove the stone. Process all the fruit in your J 80 Ultra juicer.

Combine the fruit juice with the honey and yoghurt. Divide between 4 glasses and serve.

PINEAPPLE EXOTICA

Ingrédients (for 4 glasses):

- 1 mango
- 2 limes
- 1 pineapple
- 2 oranges
- 50 g sugar
- a few ice cubes

Peel the fruit and stone the mango. Process the ingredients separately in your J80 Ultra juicer. Pour the juices into a shaker in the following order: lime, mango, pineapple and orange. Add the sugar and ice cubes. Shake vigorously for a few seconds. Serve in cocktail glasses decorated with pieces of fruit.

RASPBERRY COCKTAIL

Ingrédients (for 3 glasses):

- 500 g de raspberries
- 1 bunch white grapes
- 100 ml cane syrup

Rinse the grapes and strip them off the bunch. Process the fruit in your J 80 Ultra juicer and combine the juices with the cane syrup. Serve chilled.

OLYMPUS

Ingrédients (for 4 glasses):

- 1 large bunch white grapes
- 1 lemon
- 1 pineapple

Rinse the grapes and strip them off the bunch. Peel the pineapple and cut 3 generous slices. Put these in your J 80 Ultra juicer together with the grapes. Squeeze the lemon. Combine the juices in a shaker and serve chilled.

AUTUMN LEAVES

Ingrédients (for 4 glasses):

- ¼ litre water
- 4 apricots
- 4 plums
- 2 Williams pears
- ½ teaspoon cinnamon
- ½ lemon

Wash and stone the plums and apricots. Cut the pears into small chunks and sprinkle immediately with lemon juice to prevent them from browning. Switch your J 80 Ultra juicer on and introduce first the fruit, then the water, via the feed tube. Pour the juice into a carafe, add the cinnamon and stir. Serve with or without ice.

SWEET-AND-SAVOURY COCKTAILS

GAZPACHO

Ingrédients (serves 4):

- 500 g ripe tomatoes
- 1 cucumber
- 1 green pepper
- celery salt and pepper

Roughly peel the cucumber. Wash and deseed the green pepper. Feed the vegetables into your J 80 Ultra juicer in the following order: tomatoes, cucumber and pepper. Stir the juice to achieve a smooth consistency. Decorate with lemon slices and hand the celery salt and pepper separately.

MEDIAEVAL

Ingrédients (for 4 glasses):

- 300 g carrots
- 200 g pink radishes
- dash of olive oil
- pinch of salt

Remove the radish and carrot tops and process in your J 80 Ultra juicer. Add the salt and olive oil. Combine thoroughly before serving.

SPRING COCKTAIL

Ingrédients (for 4 glasses):

- 6 carrots
- 4 asparagus spears
- 3 sticks celery

Wash all the vegetables and cut into chunks. Process them in your J 80 Ultra juicer, starting with the asparagus. A great cocktail for the month of May, rich in vitamins, iron, calcium, phosphorus and sodium.

AUTUMN COCKTAIL

Ingrédients (for 4 glasses):

- 4 tomatoes
- 1 lemon
- 1 Williams pear
- salt and pepper

Wash and dry the tomatoes and pears. Switch your J 80 Ultra on and gradually introduce the ingredients via the feed tube. Stir in the juice of the lemon and season generously with salt and pepper.

REFRESHER COCKTAIL

Ingrédients (for 4 glasses):

- 1 pineapple
- 1 stick celery

Peel the pineapple and cut into 8 pieces. Wash the celery and cut into chunks. Process both ingredients in your J 80 Ultra juicer. Stir and serve immediately, so as to lose none of the vitamin goodness. A good cure for headaches.

MILK-BASED COCKTAILS

CARIBBEAN COCKTAIL

Ingrédients (for 4 glasses):

- 1 ripe white peach
- 1 mango
- 100 g pineapple
- ½ litre chilled milk

Wash and dry the peach. Remove the stone. Peel the pineapple and mango (remove the stone). Set aside a few chunks of fruit to decorate the glasses with fruit skewers. Process the remaining chunks in your J 80 Ultra juicer. Add the chilled milk and serve immediately.

DAIRY KIWI

Ingrédients (for 4 glasses):

- 5 kiwi fruit
- 100 g raspberries
- 50 g sugar
- ½ litre milk

Halve the kiwi fruits, scoop out the flesh and process it in your J 80 Ultra juicer. Wipe the raspberries with damp kitchen paper and process with a stick blender, adding the sugar and milk. Combine with the kiwi juice. Serve with ice in frosted glasses.

GRANNY SMITH COCKTAIL

Ingrédients (for 4 glasses):

- 5 ripe pears
- 1 Granny Smith apple
- 4 cl mint syrup
- ½ litre milk
- 4 fresh mint leaves

Wash the apple and the pears and cut into chunks. Process the pears in your J 80 Ultra juicer, followed by the apple. Combine with the milk. Put a few ice cubes in each glass, pour over a little mint syrup and top with the milk and fruit juice mixture. Decorate with a mint leaf.

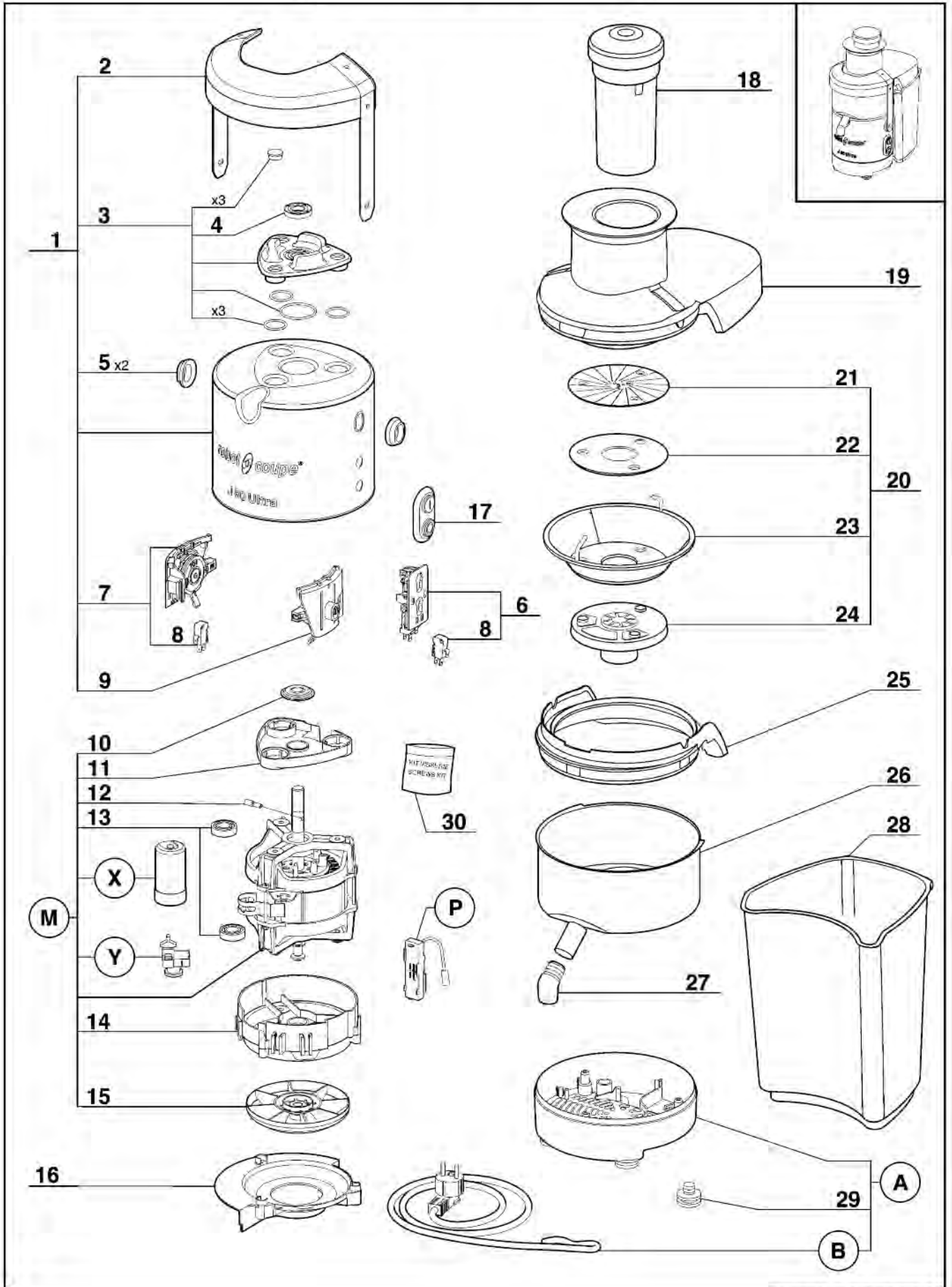

Index	Pièce / Part	Désignation	Description
1	39 895	ENS. SUPPORT MOTEUR	MOTOR SUPPORT ASSEMBLY
2	39 896	LEVIER DE BLOQUAGE	LOCKING LEVER
3	39 897	ENS. CENTRAGE DE CUVE	BOWL CENTRING
4	501 010	BAGUE D'ETANCHEITE	SHAFT SEAL
5	39 898	CACHE PALIER (x 2)	BEARING CACHE (x 2)
6	39 899	ENS. BLOC MARCHE/ARRET	ON/OFF BLOCK ASSEMBLY
7	39 900	ENS. PALIER GAUCHE	LEFT BEARING ASSEMBLY
8	502 435	INTERRUPTEUR	SWITCH
9	39 901	ENS. PALIER DROIT	RIGHT BEARING ASSEMBLY
10	39 902	DEFLECTEUR D' AXE	SHAFT DEFLECTOR
11	39 903	CENTRAGE MOTEUR	MOTOR CENTRING
12	39 904	GOUPILLE	MOTOR SHAFT PIN
13	39 905	ENS. ROULEMENTS	BALL BEARINGS KIT
14	39 906	CONDUIT DE VENTILATION	BAFFLE
15	118 512	VENTILATEUR MOTEUR	MOTOR FAN
16	39 907	DEFLECTEUR MOTEUR	MOTOR DEFLECTOR
17	39 927	ENS. TABLEAU COMMANDE	CONTROL PANEL ASSEMBLY
18	39 908	POUSSOIR	PUSHER
19	39 909	COUVERCLE	LID
20	39 910	ENS. PANIER	BASKET ASSEMBLY
21	39 911	DISQUE RAPEUR	GRATER
22	39 929	RONDELLE INCLINEE	ANGLED SPACER
23	39 912	FILTRE	SIEVE
24	39 913	MOYEU	HUB
25	39 914	COLLERETTE DE CUVE	BOWL FLANGE
26	39 915	CUVE	BOWL
27	39 916	BEC VERSEUR	SPOUT
28	39 917	COLLECTEUR DE PULPE	PULP COLLECTOR
29	39 928	PIED (x 4)	FOOT (x 4)
30	39 960	KIT VISSERIE (incluant toutes les vis du bloc moteur)	SCREWS KIT (including all screws for the motor base)

Index	Désignation	Description
A	ENS. SOCLE	BASE ASSEMBLY
B	CABLE D'ALIMENTATION	POWER CORD
M	MOTEUR	MOTOR
P	PLATINE	CIRCUIT BOARD
X	CONDENSATEUR	CAPACITOR
Y	RELAIS MOTEUR	MOTOR RELAY

Machine	Voltage	A	B	M	P	X	Y
56 009 JAP	100/50-60/1	39 918	39 890	39 930	39 894	600 089	500 296
56 005	120/60/1			39 924			
56 004	220/60/1	39 919	39 888	39 925	39 880	600 018	504 674
56 000	230/50/1			39 926			500 289
56 006 CH	230/50/1	39 920	39 893				
56 007 DK	230/50/1	39 921	39 892				
56 001 UK	230/50/1	39 922	39 889				
56 002 Aust	240/50/1	39 923	39 891				

	Français	English	Deutsch
CD	Condensateur de démarrage	Starting capacitor	Anlasskondensator
EA	Phase auxiliaire	Starting phase	Hilfsphase
EP	Phase principale	Main phase	Hauptphase
KD	Relais de démarrage	Starting relay	Anlassrelais
MA	Interrupteur MARCHÉ / ARRET	ON / OFF switch	Stop / Betriebsschalter
MF	Module de freinage	Breaking module	Bremsmodul
MO	Moteur monophasé	Single phase Motor	Motor einphasig
PTO	Protecteur thermique du moteur	Motor thermal protector	Motorthermoschutz
SW	Interrupteur sécurité étrier	Clamp safety switch	Steigbügel zur Deckelsicherheit

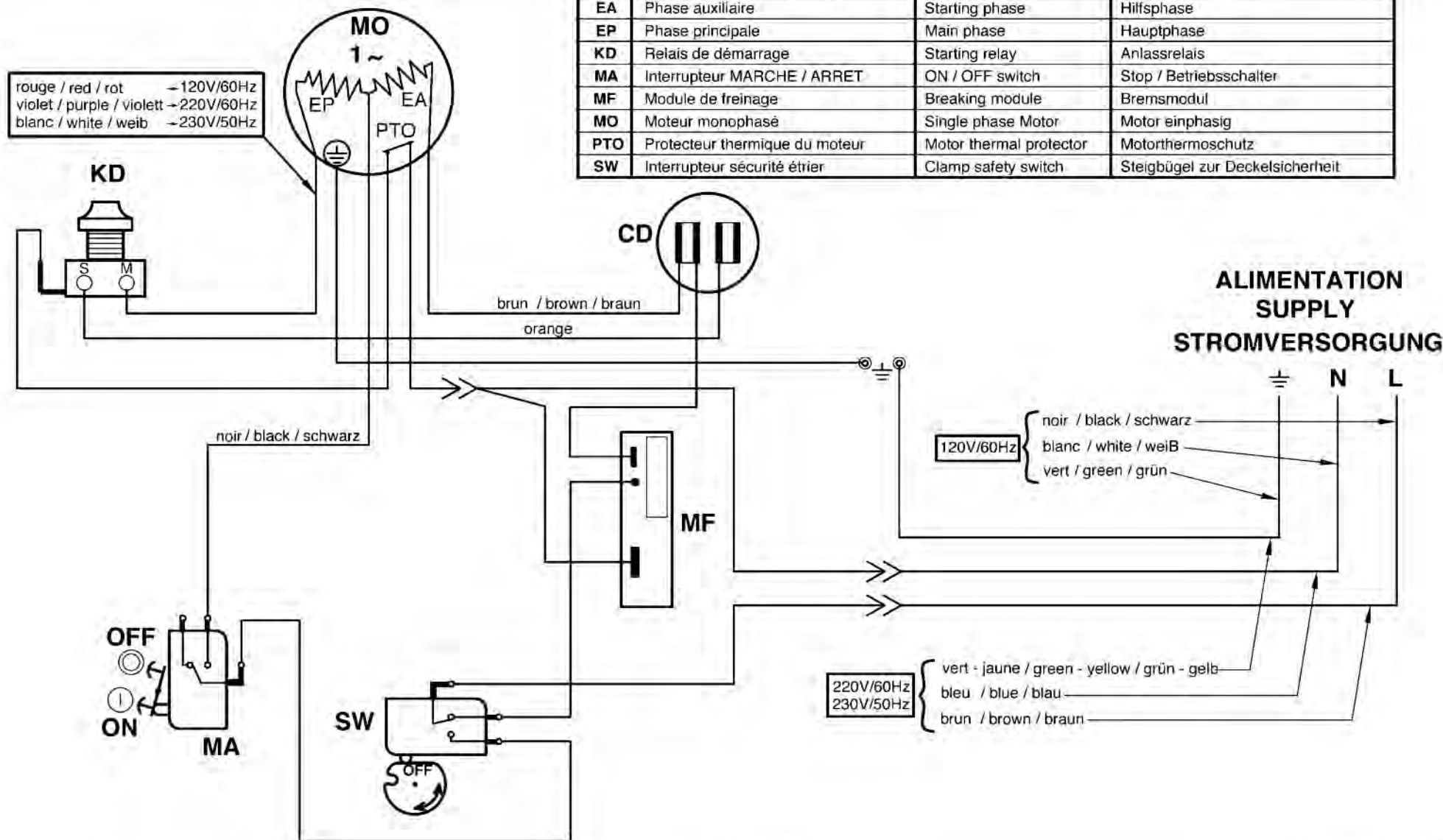



robot coupe®

MADE IN FRANCE BY ROBOT-COUBE S.N.C.

Export Department

Tel. : + 33 1 43 98 88 33

Fax : + 33 1 43 74 36 26

48, rue des Vignerons

94305 Vincennes Cedex - France

<http://www.robot-coupe.com>

email : international@robot-coupe.com

We reserve the right to alter at any time without notice the technical specifications of this appliance.
None of the information contained in this document is of a contractual nature. Modifications may be made at any time.
© All rights reserved for all countries by: ROBOT-COUBE s.n.c.